

# 100% ELECTRIC *Broom Bear*®



**ELGIN**  
Subsidiary of Federal Signal Corporation



## SAME POWERFUL BEAR. NEW GREEN ENERGY. MECHANICAL SWEEPER.

Meet your emissions and sustainability goals without compromising performance. The new Electric Broom Bear is backed by 100 years of Elgin know-how and reputation for quality. No other street sweeper gets the job done like an Elgin, and the Electric Broom Bear is no exception. With a powerful battery and efficient hydraulic system, this green machine will clean up all day. And rest assured, Elgin engineered the Electric Broom Bear to work your full shift and then some. You'll quit before it does.





## BEAST MODE GOES GREEN.

A global leader in street sweeper innovation, Elgin meets modern customer demands with advanced technology. The Electric Broom Bear eliminates emissions while reducing noise and maintenance costs without compromising powerful performance.

### Why 100% Electric Mechanical Sweeper?

- 100% electric, zero emission mechanical sweeper
- Strong battery capacity - 400 kWh
- Good turning radius and maneuverability
- Better payload carrying capacity
- Reduced maintenance to maximize uptime
- Backed by a strong and established dealer network
- State and federal grants and incentives available

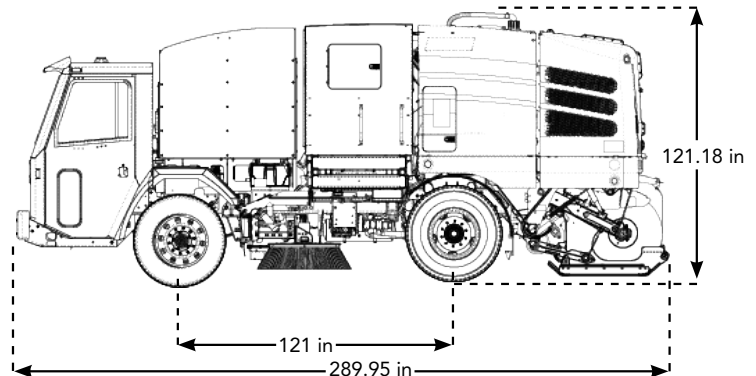

# INNOVATIONS AT WORK

A closer look at the Elgin Electric Broom Bear reveals innovative design features, systems, and components. These not only simplify operation and improve performance but also make maintenance and servicing faster and easier. The result is the optimal efficiency of your operations, as you reduce maintenance requirements and downtime. The Electric Broom Bear brings you an array of innovative systems including:



## Battery and Motor Overview

---

The heart of the chassis is the 400 kWh, lithium iron phosphate (LFP) battery. The battery has a 5 year warranty and is designed for more than 2,500 full charging cycles. The BorgWarner Cascadia motor produces 300 continuous horsepower and has a maximum torque of 1,700 ft lbs.



## Battery Charging

---

Charging can be done using the on board SAE 1772 CCS port which accommodates Level 2 or Level 3 chargers. Recharging of the battery will vary based on environmental temperature, charger level and charger kilowatts but can be done as quickly as 3 hours using a 125 kW Level III Charger. Like many EV's on the market, the Electric Broom Bear comes standard with regenerative braking to extend the time between charging sessions.



## Memory Sweep

---

Elgin's exclusive Memory Sweep feature allows the operator to resume ALL previous sweeper settings with one-touch control. The feature provides a multi-screen display for tilt angle, broom hours, water level, and diagnostic information.



## Pause Sweep

---

To further improve both battery efficiency and sweep component life, the sweep system can automatically pause when the sweeper is not sweeping and re-engages immediately upon vehicle movement without leaving any material behind.

# BUILT TO LAST

## Large, Variable Dump Height Hopper

The hopper has a capacity of 4.5 cubic yards (3.4 m<sup>3</sup>) and a variable dump height between 38" and 11'2". Payload can be offloaded as low as 38" (965 mm) or the double scissor lift can raise the hopper to a maximum height of 11'2" (3,404 mm) When offloading into a dump truck 11" (279 mm) side shift, combined with a 50° dump angle ensures material is deposited near the center of the truck. All controls are operated from the in-cab control console.



## Main Broom

The main broom is attached to a fully floating trailing arm to better conform to road contours. Performance is optimized using mechanical main broom suspension that dynamically adjusts to various road conditions while on-the-go. Lift and lower functions are controlled from the cab. Main broom arm bearings are sealed, can be re-lubricated and are self-aligning for self-adjustment when experiencing an uneven load which decreases wear and increases main broom life.



## Side Brooms

46" (1,188 mm) trailing arm, free-floating side brooms offer four-way motion and protection against damaging impacts. Pneumatic lift and extension control enhances performance while sweeping within a 10' (3,048 mm) wide path.



## Simple, Easy-Access Maintenance

The Broom Bear was designed so that systems are accessible and easy to service. The hydraulic system with o-ring face seal fittings is designed for long life and leak-free operation. Heavy-duty waterproof electrical connectors and color-coded wires have stamped identification for quick location during troubleshooting.



# UNIQUE APPLICATION VERSATILITY

The Electric Broom Bear comes standard with a squeegee type conveyor designed to provide versatile and reliable performance in a wide range of applications including aggregate and granular material pick up of gravel and millings, ideal for road construction contractors as well as general municipal sweeping, trash, leaves, and other organics.

A belt conveyor is also available for applications such as highway sweeping and general municipal sweeping where large debris is encountered or when high-loading rates are needed.



## ELGIN SQUEEGEE CONVEYOR

- Chain side-plate constructed from hardened steel for long life and smooth operation.
- Three-piece design for easy service without removing complete assembly.
- Thick, multi-ply rubber-edged flights efficiently moves debris into hopper.
- Unique, interlocking, wavy-plate joint design prevents excessive wear and “thumping” over plate seams.
- Abrasion-resistant steel floor for durability.
- Direct-drive hydraulic motor for optimal power transfer to conveyor system.



## OUR COMMITMENT TO QUALITY ONLY BEGINS WITH OUR EQUIPMENT

The Elgin Electric Broom Bear is manufactured in an ISO 9001 certified, advanced industrial plant with over 208,000 sq. ft. (19,350 sq. m.) of space. We employ the latest technology to build the most reliable equipment, including high-precision laser cutters, efficient, accurate computer numerical controls (CNC), and a sophisticated powder coating system.

When you build a quality product you can back it up with a full one-year, unlimited hours warranty. Elgin also backs up your investment with superior local service and support. Our goal is to keep your machine—and your entire operation—up and running.

The Electric Broom Bear can be customized to your unique requirements to meet local standards and regulations by means of a broad selection of configurations, options and accessories.

Through our international dealer network, we maintain a vast inventory of spare parts and offer fast shipment to any region of the world.

Altogether, the rugged, reliable Elgin Electric Broom Bear is easy to operate, easy to maintain, and an easy choice when you are looking for quality equipment that is built to last.



### The Electric Broom Bear Truck Mounted Mechanical Sweeper Specifications

Chassis	Low Voltage Electrical	Dust Control System	Hydraulic System	Conveyor
<b>Make</b> Battle Motors <b>Model</b> LNT <b>Motor</b> Cascadia HVH410 <b>Charge System</b> J1772 CCS Charge Port <b>ePTO</b> 13-27 kW @2750 rpm <b>Battery</b> Lithium Ion 400kWh, 700V	<b>Voltage</b> 12 V/negative ground <b>Battery</b> Group 31, 1900 CCA <b>Wiring</b> Hot stamp identified with weatherproof connectors	<b>PM-10 Compliant Tank Capacity</b> 360 gallons (1,362 L) <b>Pump</b> Triplex Positive Displacement <b>Spray Nozzles</b> 3 across main broom and over each gutter broom	<b>Sweep System Pump</b> Quad gear pump <b>Capacity</b> 26.7 gpm <b>Reservoir Capacity</b> 23 gal <b>Inlet Strainer</b> 100 mesh <b>Return Filter</b> 6 micron <b>Breather</b> 10 micron <b>Cooler</b> Externally mounted <b>Valves</b> Electro-hydraulic	<b>Type</b> Squeegee with replaceable rubber edging <b>Material</b> (elevator bottom) Bolt-in multi section abrasion resistant steel plates <b>Speed</b> Constant, forward and reverse <b>Flexibility</b> Lift independent

# 100% ELECTRIC Broom Bear<sup>®</sup>

Go green without compromising power. The new Electric Broom Bear is built on 100 years of Elgin quality and our commitment to performance. So you can eliminate emissions, reduce noise, cut maintenance costs and still complete a day's work on one charge. The powerful battery and efficient hydraulic system mean you'll quit before it does.

Featuring:

- 100% electric, zero emission mechanical sweeper
- Strong battery capacity - 400 kWh
- Good turning radius and maneuverability
- Better payload carrying capacity
- Reduced maintenance to maximize uptime
- Backed by a strong and established dealer network
- State and federal incentives available



Elgin Sweeper • 1300 West Bartlett Road, Illinois 60120 USA  
Phone 847-741-5370 | Parts & Service 877-800-1111  
[www.elginsweeper.com](http://www.elginsweeper.com)

Specifications subject to change without notice. Some products shown with optional equipment. Elgin® is a registered trademark of Elgin Sweeper.

Products may be covered by one or more United States Patents and/or pending patent applications.

Elgin Sweeper is a subsidiary of Federal Signal Corp. | Federal Signal Corp. is listed in the NYSE by the symbol FSS.  
Effective Date 07/23 P/N 0705443-C ©2023 Elgin Sweeper Printed in the USA